

**Lista parti di ricambio  
Spare parts list  
Liste des pièces détachées  
Ersatzteilliste**

**CA 40**

**Ref. CA40/2/2007/SAP**

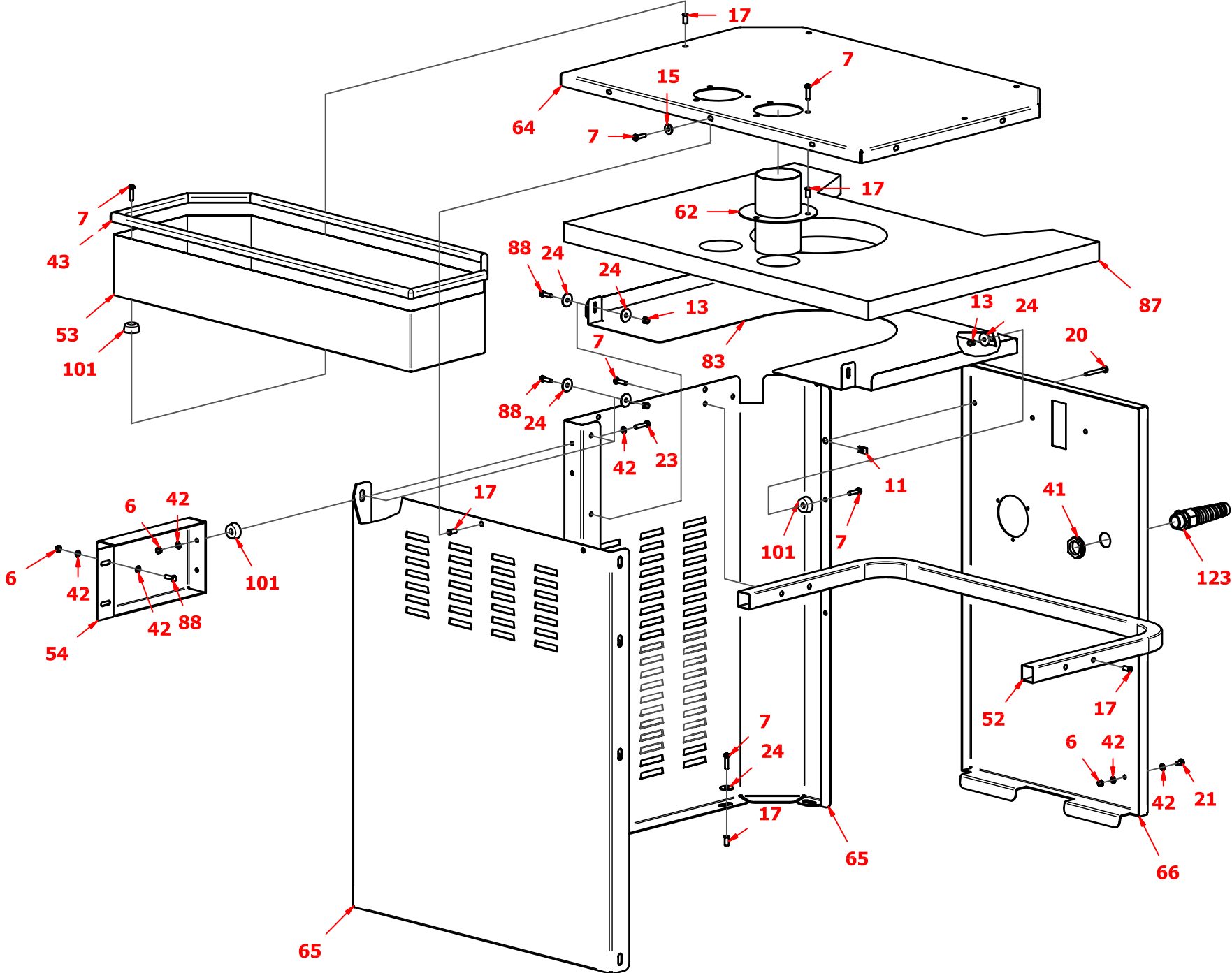



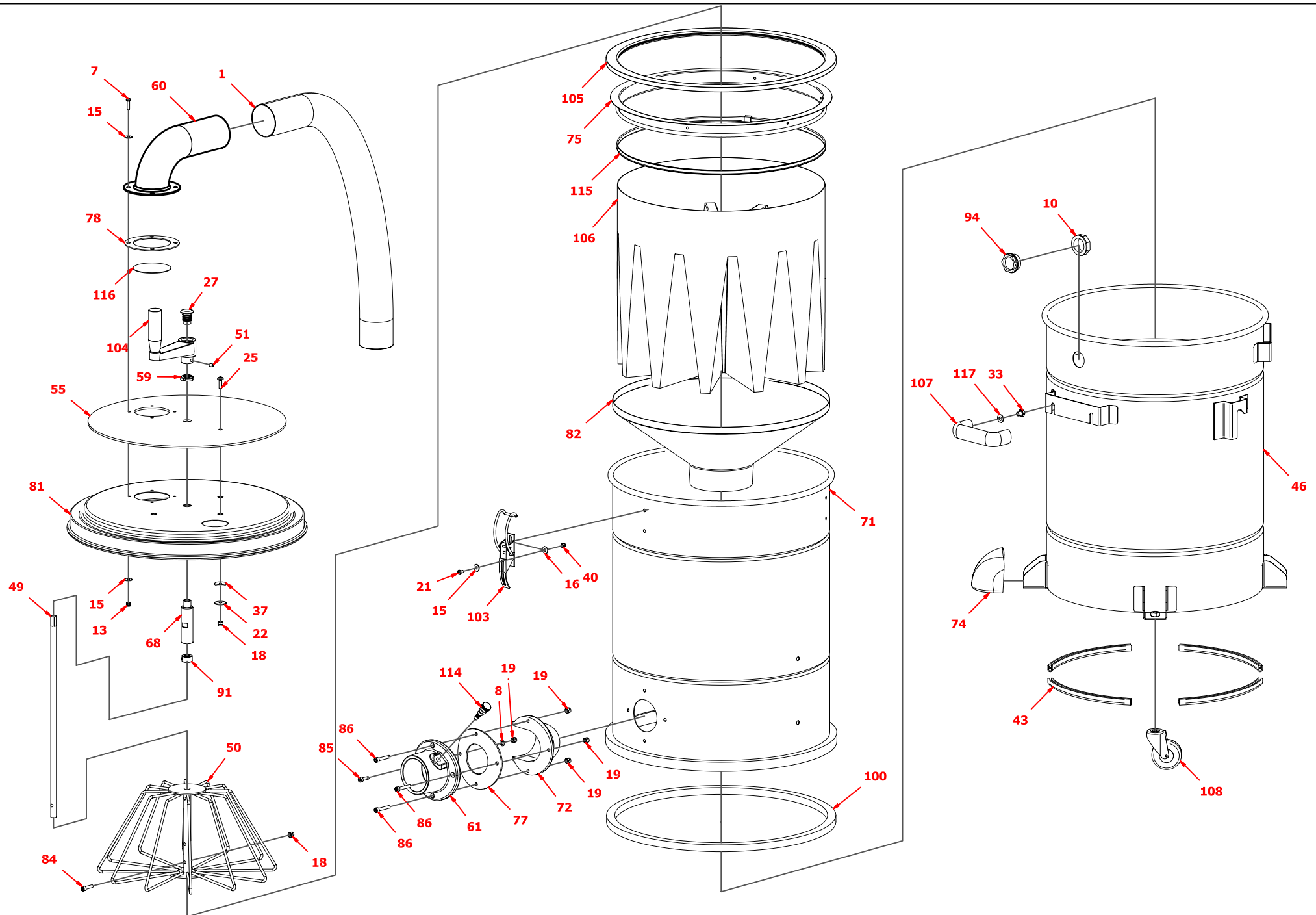

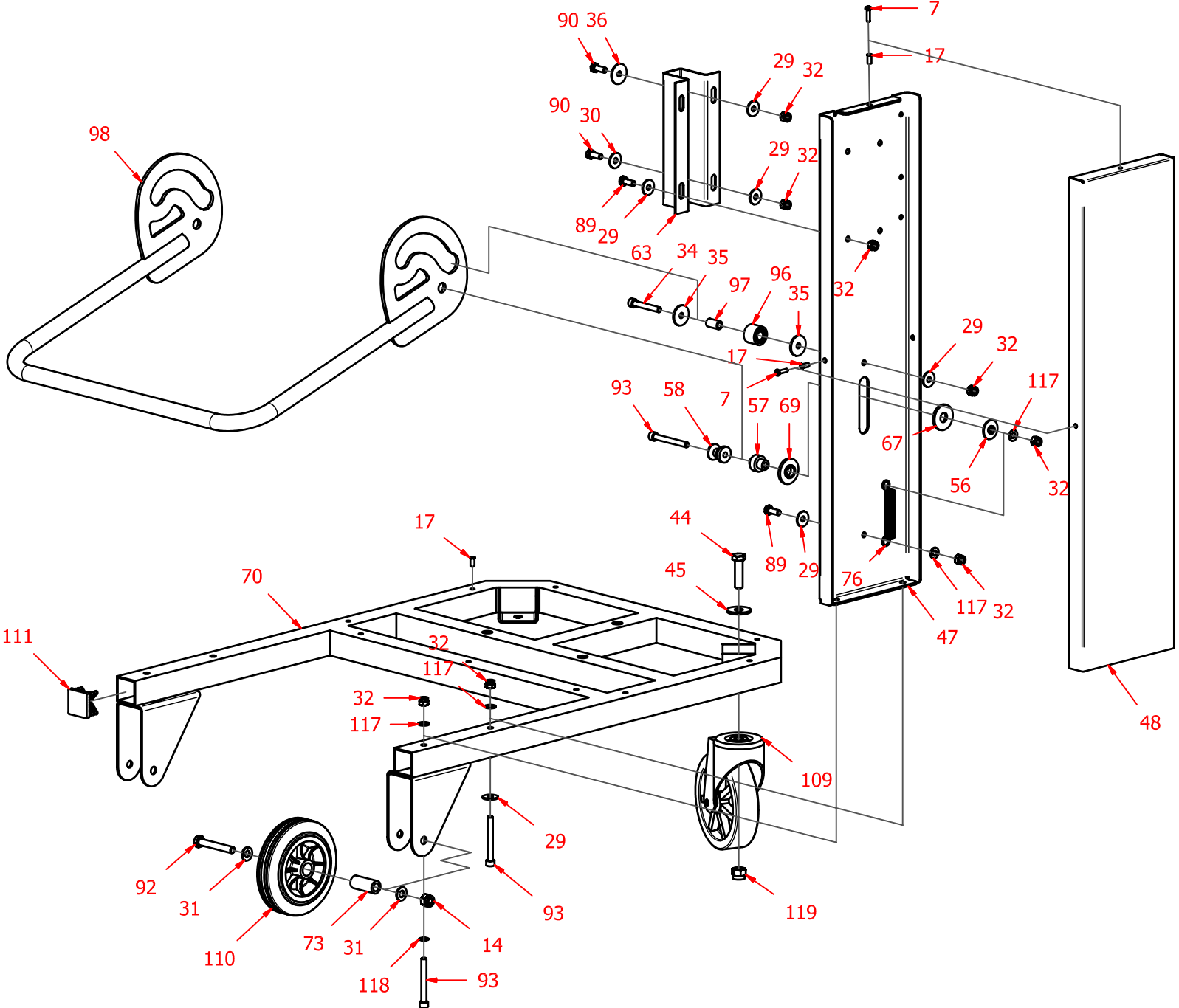

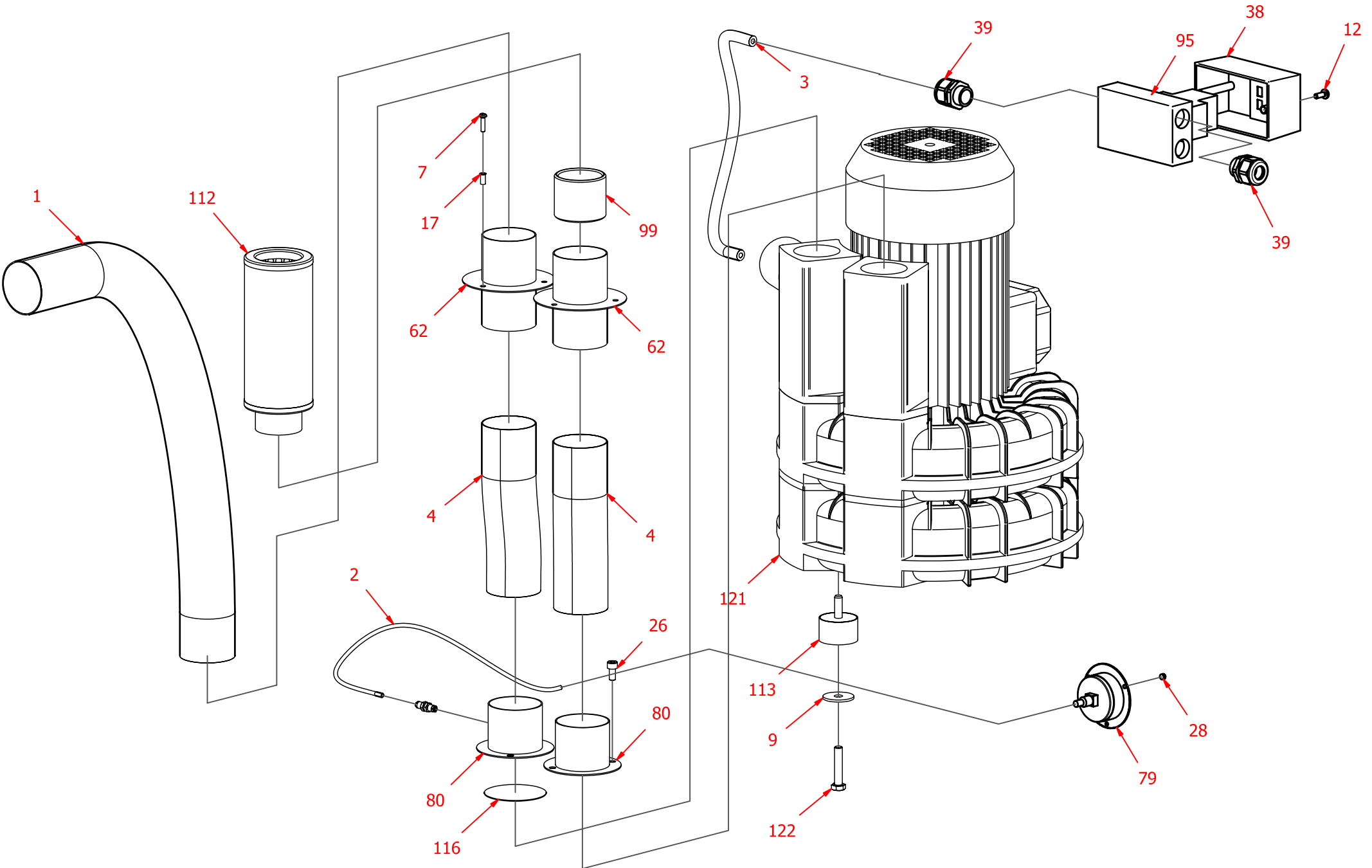

Posizione Item Position Position	Codice Part No. Pezzo No. Teile Nr.	Descrizione	Description	Designation	Benennung
1	418202	TUBO D.70 DI RACCORDO L.900MM	JUNCTION TUBE D.50 L.900MM	TUBE DE JONCTION D.70 L.900MM	VERZWEIGUNG SCHLAUCH D.70 L.900MM
2	418210	TUBO EXTRAFLEX 6x8 NERO	HOSE EXTRAFLEX 6x8 BLACK	TUYAU EXTRAFLEX 6x8 NOIR	SCHLAUCH EXTRAFLEX 6x8 SCHWARZER
3	417126	CAVO CABLATO 4x1,5M	CABLE 4x1,5M	CÂBLE 4x1,5M	KABEL 4x1,5M
4	417942	TUBO D.70 RACCORDO TURBINA	HOSE D. 70	TUYAU D.70	SCHLAUCH D.70
6	417267	DADO M5 ZNT	NUT M5 ZNT	ECROU M5 ZNT	MUTTER M5 ZNT
7	408855	VITE M5x20 TC T.C. ZNT	SCREW M5x20 TC T.C. ZNT	VIS M5x20 TC T.C. ZNT	SCHRAUBE M5x20 TC T.C. ZNT
8	417992	RONDELLA D.6,4x12 INOX	WASHER D.6,4x12 INOX	RONDELLE D.6,4x12 INOX	SCHEIBE D.6,4x12 INOX
9	417978	RONDELLA D.10x40 ZNT	WASHER D.10x40 ZNT	RONDELLE D.10x40 ZNT	SCHEIBE D.10x40 ZNT
10	417514	GHIERA 1" NYLON	RING NUT 1" NYLON	ÉCROU D'ANNEAU 1" NYLON	RING-NUSS 1" NYLON
11	417906	PRESTOLA	CLIP FOR SCREW	AGRAFE POUR LA VIS	KLAMMER FÜR SCHRAUBE
12	418317	VITE M6x16 TC T.C. ZNT	SCREW M6x16 TC T.C. ZNT	VIS M6x16 TC T.C. ZNT	SCHRAUBE M6x16 TC T.C. ZNT
13	417259	DADO AUTOBLOCCANTE M5 ZNT	LOCK NUT M5 ZNT	ÉCROU À BLOCAGE AUTOMATIQUE M5 ZNT	GEGENMUTTER M5 ZNT
14	409089	DADO M10 ZNT	NUT M10 ZNT	ECROU M10 ZNT	MUTTER M10 ZNT
15	417987	RONDELLA D.5,5x15 ZNT	WASHER D.5,5x15 ZNT	RONDELLE D.5,5x15 ZNT	SCHEIBE D.5,5x15 ZNT
16	417986	RONDELLA D.5,5x15 INOX	WASHER D.5,5x15 INOX	RONDELLE D.5,5x15 INOX	SCHEIBE D.5,5x15 INOX
17	417609	INSERTO FILETTATO M5 D.7,5	THREADED INSERT M5 D.7,5	INSERTION FILETÉE M5 D.7,5	GEWINDEEINSATZ M5 D.7,5
18	409082	DADO AUTOBLOCCANTE M6 ZNT	LOCK NUT M6 ZNT	ECROU A BLOCAGAGE AUTOMATIQUE M6 ZNT	GEGENMUTTER M6 ZNT
19	409082	DADO AUTOBLOCCANTE M6 ZNT	LOCK NUT M6 ZNT	ECROU A BLOCAGAGE AUTOMATIQUE M6 ZNT	GEGENMUTTER M6 ZNT
20	418283	VITE AUTOF.4,8x42 TC T.C. ZNT	SELF-TAPPING SCREW 4,8x42 TC T.C. ZNT	VIS AUTOTARAUEUSE 4,8x42 TC T.C. ZNT	SELBSTSCHNEIDENDE SCHRAUBE 4,8x42 TC T.C. ZNT
21	418311	VITE M5x10 TC T.C. ZNT	SCREW M5x10 TC T.C. ZNT	VIS M5x10 TC T.C. ZNT	SCHRAUBE M5x10 TC T.C. ZNT
22	417995	RONDELLA D.6,6x24 ZNT	WASHER D.6,6x24 ZNT	RONDELLE D.6,6x24 ZNT	SCHEIBE D.6,6x24 ZNT
23	408856	VITE M5x25 TC T.C. ZNT	SCREW M5x25 TC T.C. ZNT	VIS M5x25 TC T.C. ZNT	SCHRAUBE M5x25 TC T.C. ZNT
24	417988	RONDELLA D.5,5x20 INOX	WASHER D.5,5x20 INOX	RONDELLE D.5,5x20 INOX	SCHEIBE D.5,5x20 INOX
25	408862	VITE M6x20 TC T.C. ZNT	SCREW M6x20 TC T.C. ZNT	VIS M6x20 TC T.C. ZNT	SCHRAUBE M6x20 TC T.C. ZNT
26	415765	VITE BRUGOLA M8x16 ZNT	SOCKET HEAD SCREW M8x16 ZNT	VIS ALLEN M8x16 ZNT	IMBUSSCHRAUBE M8x16 ZNT
27	418142	COPERCHIO PER MANIGLIA	STOPPER x HANDLE	COUVERCLE POUR POIGNÉE	DECKEL FÜR GRIFF
28	417966	RIVETTO 3,8x14 ALLUMINIO	ALUMINUM RIVET 3,8x14	RIVET EN ALUMINIUM 3,8X14	ALUMINIUMNIET 3,8X14
29	418001	RONDELLA D.8x24 ZNT	WASHER D.8x24 ZNT	RONDELLE D.8x24 ZNT	SCHEIBE D.8x24 ZNT
30	418000	RONDELLA D.8x24 INOX	WASHER D.8x24 INOX	RONDELLE D.8x24 INOX	SCHEIBE D.8x24 INOX
31	417976	RONDELLA D.10,5x20 ZNT	WASHER D.10,5x20 ZNT	RONDELLE D.10,5x20 ZNT	SCHEIBE D.10,5x20 ZNT
32	409085	DADO AUTOBLOCCANTE M8 ZNT	LOCK NUT M8 ZNT	ECROU A BLOCAGAGE AUTOMATIQUE M8 ZNT	GEGENMUTTER M8 ZNT
33	418323	VITE M8x10 TE ZNT	SCREW M8x10 TE ZNT	VIS M8x10 TE ZNT	SCHRAUBE M8x10 TE ZNT
34	418300	VITE BRUGOLA 8x40 ZNT	SOCKET HEAD SCREW 8x40 ZNT	VIS ALLEN 8x40 ZNT	IMBUSSCHRAUBE 8x40 ZNT
35	418003	RONDELLA D.8x40 ZNT	WASHER D.8x40 ZNT	RONDELLE D.8x40 ZNT	SCHEIBE D.8x40 ZNT
36	418002	RONDELLA D.8x32 INOX	WASHER D.8x32 INOX	RONDELLE D.8x32 INOX	SCHEIBE D.8x32 INOX
37	417996	RONDELLA D.6x24 GOMMA	WASHER D.6x24 RUBBER	RONDELLE EN CAOUTCHOUC D.6x24	GUMMISCHEIBE D.6x24
38	417087	CASSETTA PER INTERRUTTORE SALVAMOTORE	BOX FOR MOTOR SWITCH	BOÎTE POUR LE COMMUTATEUR DE PROTECTION MOTEUR	KASTEN FÜR MOTORSCHUTZSCHALTER
39	416981	BOCCHETTA PER CASSETTA	BOX UNION	EMBOUCHURE POUR BOÎTE	MÜNDUNG FÜR KISTE
40	417262	DADO CIECO M5 INOX	CAP NUT M5	ÉCROU BORGNE M5	BLINDMUTTER M5 INOX

Posizione Item Position Position	Codice Part No. Pezce No. Teile Nr.	Descrizione	Description	Designation	Benennung
48	417193	COPERCHIO SPALLA TRI 30/55/75 _GRIGIO RAL 7030	SHOULDER COVER RAL 7030	COUVERTURE D'ÉPAULE AL 7030	SCHULTER-ABDECKUNG AL 7030
49	416871	ASTA CESTINO TENDIFILTRO	SPINDLE FOR FILTER TIGHTENER	AXE POUR TENDEUR DE FILTRE	SPINDEL FÜR SPANNER FÜR FILTER
50	417139	CESTELLO TENDI FILTRO	FILTER TIGHTENER	PANIER TENDEUR DU FILTRE	KORB SPANNSTÜCK FÜR FILTER
51	411961	GRANO A BRUGOLA 6x10	GRUB SCREW 6x10	GOUPILLE 6x10	GEWINDESTIFT 6x10
52	417762	MANIGLIA	HANDLE	POIGNÉE	HANDGRIFF
53	417132	CESTINO PORTA UTENSILI	BASKET FOR TOOLS	PANIER POUR OUTILS	KORB FÜR WERKZEUGE
54	418155	SUPPORTO SPALLA	SHOULDER SUPPORT	ÉPAULE DE SUPPORT	TRÄGERSCHULTER
55	417960	RINFORZO COPERCHIO GRIGIO RAL 7030	COVER PLATE RAL 7030	RENFORT DE PLAT DU COUVERCLE RAL 7030	VERSTÄRKUNG RAL 7030
56	417858	PIATTELLO BLOCCA MANIGLIA	NYLON WASHER FOR HANDLE	RONDELLE EN NYLON POUR LA POIGNÉE	NYLONUNTERLEGSSCHEIBE FÜR HANDGRIFF
57	417860	PIATTELLO DISTANZIALE	SPACER	ENTRETOISE	DISTANZSTÜCK
58	417604	INCASTRO SOLLEVAMENTO	JOINT FOR LIFTING GEAR	JOINT POUR LE DISPOSITIF DE SOULÈVEMENT	FUGE FÜR DIE STEIGENVORRICHTUNG
59	417519	GHIERA FILETTATA M 17 passo 1	THREADED METAL RING M17	ANNEAU FILETÉ M17 EN MÉTAL	VERLEGTER METALLRING M17
60	417247	CURVA ASPIRAZIONE D.70	CURVE D.70	COURBE D.70	KURVE D.70
61	204680	BOCCHETTONE ASPIRAZIONE	ALUMINIUM SUCTION HOSE INLET	ALLUMINIUM BUSE DE SORTIE DE CUVE	ALLUMINIUM BOTTICHANSCHLUSS
62	417469	FLANGIA PASSAPARETE	FLANGE	BRIDE	FLANSCH
63	418151	SUPPORTO INVOLUCRO SUPERIORE	SUPPORT FOR VACUUM CHAMBER	SUPPORT DE CHAMBRE DE VIDE	HALTERUNG FÜR VAKUUMRAUM
64	417172	COPERCHIO CARROZZERIA	CHASSIS COVER	COUVERTURE DE CHÂSSIS	ABDECKUNG FÜR KARROSSERIE
65	417026	CARROZZERIA	CHASSIS	CHÂSSIS	KARROSSERIE
66	417182	COPERCHIO PORTA INTERRUPTORE	SWITCH PANEL	PANNEAU POUR COMMUTATEUR	BRETT FÜR SCHALTER
67	417298	DISTANZIALE NYLON	NYLON SPACER	ENTRETOISE EN NYLON	NYLONDISTANZSTÜCK
68	417291	DISTANZIALE H72	SPACER H72	ENTRETOISE D72	DISTANZSTÜCK H72
69	417859	PIATTELLO D.36 NYLON	NYLON DISH D.36	PLAT EN NYLON D.36	NYLONTELLER D.36
70	418187	TELAIO GRIGIO RAL 7030	CHASSIS RAL 7030	CHASSIS RAL 7030	CHASSIS RAL 7030
71	417679	INVOLUCRO SUPERIORE	INOX VACUUM CHAMBER	CHAMBRE DE VIDE INOX	VAKUUMRAUM INOX
72	204692	BOCCHETTONE INTERNO	ALUMINIUM BAFFLE	ALLUMINIUM DÉFLECTEUR DE BUSE	ALLUMINIUM ABLENKBLENDE
73	417300	DISTANZIALE RUOTA FISSA	SPACER FOR WHEEL	ENTRETOISE POUR ROUE	DISTANZSTÜCK FÜR RAD
74	417215	COPRI BULLONE RUOTE FUSTO 100L	BOLT COVER	COUVERTURE DE BOULON	SCHRAUBBOLZEN-ABDECKUNG
75	416896	ANELLO PORTA-FILTRO	METAL RING FOR FILTER	ANNEAU EN MÉTAL POUR LE FILTRE	METALLRING FÜR FILTER
76	417779	MOLLA SOLLEVAMENTO	SPRING FOR LIFTING GEAR	RESSORT POUR LE DISPOSITIF DE SOULÈVEMENT	FEDER FÜR DIE STEIGENVORRICHTUNG
77	417585	GUARNIZIONE PER BOCCHETTONE 97.029	GASKET FOR ALUMINIUM MOUTH 97.029	JOINT POUR ALLUMINIUM BUSE DE SORTIE DE CUVE	DICHTUNG FÜR ALLUMINIUM BOTTICHANSCHLUSS
78	417586	GUARNIZIONE	GASKET	JOINT	DICHTUNG
79	418342	VUOTOMETRO	VACUUM GAUGE	MESURE DE VIDE	VAKUUMLEHRE
80	417465	FLANGIA D.70 PER TURBINA	FLANGE D.70 FOR TURBINE	BRIDE D.70 POUR LA TURBINE	FLANSCH D.70 FÜR TURBINE
81	417201	COPERCHIO	COVER	COUVERTURE	ABDECKUNG
82	401048	CONO CICLONE	CYCLONE CONE	CÔNE DE CYCLONE	ZYKLON KEGEL
83	417824	PANNELLO SEPARATORE	SEPARATOR PANEL	PANNEAU SÉPARATEUR	SEPARATOR-VERKLEIDUNG
84	418291	VITE BRUGOLA M8x15 ZNT	SOCKET HEAD SCREW M8x15 ZNT	VIS ALLEN M8x15 ZNT	IMBUSSCHRAUBE M8x15 ZNT
85	418290	VITE BRUGOLA M6x20 INOX	SOCKET HEAD SCREW M6x20 INOX	VIS ALLEN M6x20 INOX	IMBUSSCHRAUBE M6x20 INOX
86	418292	VITE BRUGOLA M6x35 INOX	SOCKET HEAD SCREW M6x35 INOX	VIS ALLEN M6x35 INOX	IMBUSSCHRAUBE M6x35 INOX
87	417460	FIREFLEX PER SEPARATORE	ISOLATION RING FOR SEPARATOR	ANNEAU D'ISOLEMENT POUR LE SÉPARATEUR	SCHALLSCHUTZMATTE FÜR SEPARATOR

Posizione Item Position Position	Codice Part No. Piece No. Teile Nr.	Descrizione	Description	Designation	Benennung
88	407645	VITE M5x16 ZNT	SCREW M5x16 ZNT	VIS M5x16 ZNT	SCHRAUBE M5x16 ZNT
89	408670	VITE M8x20 TE ZNT	SCREW M8x20 TE ZNT	VIS M8x20 TE ZNT	SCHRAUBE M8x20 TE ZNT
90	408671	VITE M8x20 TE INOX	SCREW M8x20 TE INOX	VIS M8x20 TE INOX	SCHRAUBE M8x20 TE INOX
91	416887	ANELLO DI FISSAGGIO	HOLDING RING	ANNEAU DE FIXATION	HALTERING
92	408718	VITE M12x65 TE ZNT	SCREW M12x65 TE ZNT	VIS M12x65 TE ZNT	SCHRAUBE M12x65 TE ZNT
93	418302	VITE BRUGOLA M8x70 ZNT	SOCKET HEAD SCREW M8x65 ZNT	VIS ALLEN M8x65 ZNT	IMBUSSCHRAUBE M8x65 ZNT
94	417606	INDICATORE DI LIVELLO M35 x 1,5	WATERLINE DETECTOR M35 x 1,5	INDICATEUR DE NIVEAU M35 x 1,5	DETEKTOR DES WASSERSTANDES M35 x 1,5
95	417627	INTERRUTTORE SALVAMOTORE	OVERLOAD CUTOUT SWITCH	COMMUTATEUR DE COUPE-CIRCUIT DE SUR	MOTORSCHUTZSCHALTER
96	417257	CUSCINETTO A RULLI D.29x22xF14	ROLLER BEARING D.29x22xF14	COUSSINET À ROULEAUX D.29x22xF14	ROLLENLAGER D.29x22xF14
97	416990	BUSSOLETTA D.12,8x23xF8,2	BUSH D.12,8x23xF8,2	DOUILLE D.12,8x23xF8,2	TÜLLE D.12,8x23xF8,2
98	417751	MANIGLIA SOLLEVAMENTO FUSTO	LIFTING HANDLE	POIGNÉE DE LEVAGE	HEBEGRIFF
99	422382	MANICOTTO ACCIAIO FILETTATO 2"	THREADED STEEL COUPLING 2"	ACCOUPLLEMENT EN ACIER FILETÉ 2"	GEZOGENE STAHLKUPPLUNG 2 "
100	417536	GUARN.MOUSSE H15x20 ADESIVA _ANTIOLIO DA 2 METRI	ADHESIVE OIL RESISTANT SPONGE RUBBER GASKET H15x20 2M	ADHÉSIF. HUILE RÉSISTANTE, GARNITURE DE CAOUTCHOUC SPONGIEUX H15x20 2 m	KLEBER, ÖL BESTÄNDIG, SCHWAMMGUMMI- DICHTUNG H15x20 2 m
101	417288	DISTANZIALE H10	SPACER H10	ENTRETOISE D10	DISTANZSTÜCK H10
102	417840	PASSACAVO	CHOCK	PASSAGE POUR CÂBLE	KABELDURCHGANG
103	417505	GANCIO CHIUSURA ACCIAIO	STEEL LATCH	CROCHET DE FERMETURE	VERSCHLUSSBUEGEL
104	417755	MANIGLIA SCUOTI FILTRO	HANDLE FOR FILTER SHAKER	POIGNÉE POUR LE TREMBLEUR DE FILTRE	HANDGRIFF FÜR FILTER-SCHÜTTEL- APPARAT
105	401051	GUARNIZIONE ANELLO FILTRO STELLARE	GASKET FOR METAL RING	JOINT POUR L'ANNEAU EN MÉTAL	DICHTUNG FÜR METALLRING
106	405422	FILTRO STELLARE TELA	STAR SHAPED CLOTH FILTER	FILTRE ETOILE DE TISSU	FILTER STOFFSTERN
107	417748	MANIGLIA INVOLUCRO 100L	HANDLE FOR TANK 100L	POIGNÉE POUR LE RÉSERVOIR 100L	HANDGRIFF FÜR BEHÄLTER 100L
108	418030	RUOTA PIROETTANTE 60x24	CASTOR 60x24	ROUE PIVOTANTE 60x24	LENKROLLE 60x24
109	418029	RUOTA PIROETTANTE D. 150/40-80	CASTOR D.150/40-80	ROUE PIVOTANTE D.150/40-80	LENKROLLE D.150/40-80
110	418007	RUOTA 150/40-80	WHEEL 150/40-80	RUOE 150/40-80	RAD 150/40-80
111	417927	PUNTALE 40x40	SQUARE CAP 40x40	COUVERCLE CARRÉ 40x40	VIERECKIGER DECKEL 40x40
112	401054	SILENZIATORE FILETT. 2"	METAL SILENCER THREAD 2"	SILENCIEUX EN MÉTAL FILETAGE 2"	METALLSCHALLDÄMPFER DRAHTZIEHEN 2 "
113	416919	ANTIVIBRANTE D-50xh30-M10-FEM.FEM.	VIBRATION DAMPER D-50xh30-M10-F.F.	AMORTISSEUR DE VIBRATION D-50xh30- M10-F.F.	ERSCHÜTTERUNG DÄMPFER D-50xh30-M10- F.F.
114	417868	PISTONCINO A MOLLA	SPRING PISTON TYPE GN.35041	PISTON AVEC LE RESSORT	KOLBEN MIT FRÜHLING
115	401053	FASCETTA BLOCCA FILTRO ACCIAIO INOX	INOX GIRDLE FOR FILTER	CEINTURE D'INOX POUR LE FILTRE	INOX GÜRTEL FÜR FILTER
116	417951	RETE PROTEZIONE TURBINA D.82	NET PROTECTION TURBINE D.82	FILET DE PROTECTION DE TURBINE D.82	NETZ DES TURBINENSCHUTZES D.82
117	417999	RONDELLA D.8x17 ZNT	WASHER D.8x17 ZNT	RONDELLE D.8x17 ZNT	SCHEIBE D.8x17 ZNT
118	417998	RONDELLA D.8x17 DENTEL.INT/ ZNT	TOOTHED LOCK WASCHER D.8x17 ZZ	RONDELLE DENTÉ D.8x17 ZZ	GEZAHNTE SCHEIBE D.8x17 ZZ
119	409092	DADO AUTOBLOCCANTE M12 ZNT	LOCK NUT M12 ZNT	ECROU A BLOCAGAGE AUTOMATIQUE M12 ZNT	GEGENMUTTER M12 ZNT
121	418242	TURBINA 4,0 HP	TURBINE 4,0 HP	TURBINE 4,0 HP	TURBINE 4,0 HP
123	417127	CAVO 4x1,5 10 M	CABLE 4x1,5 10 M	CÂBLE 4x1,5 10 M	KABEL 4x1,5 10 M



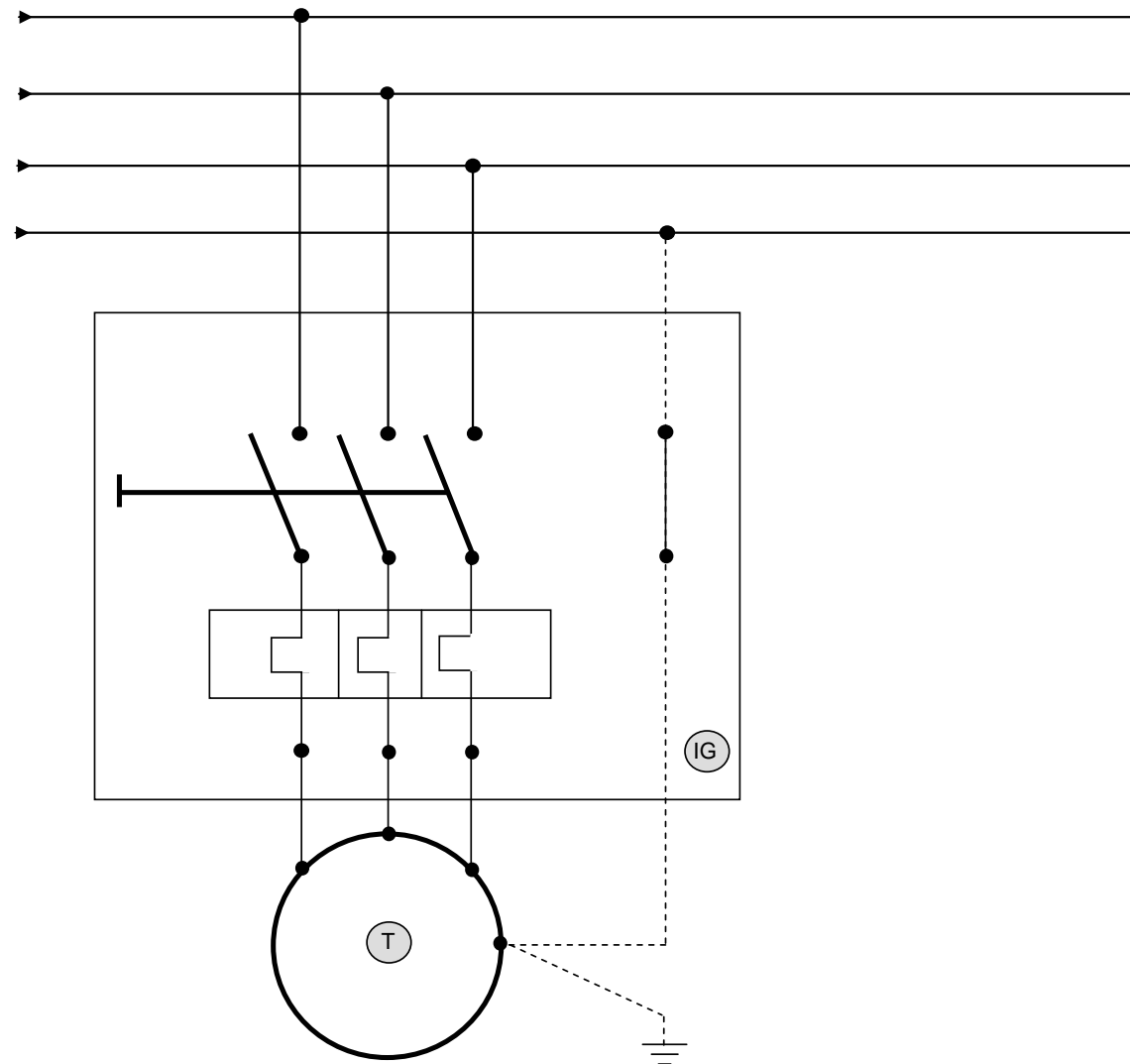

Posizione Item Position Position	Codice Part No. Piece No. Teile Nr.	Descrizione	Description	Designation	Benennung
IG		INTERUTTORE MAGNETO-TERMICO	THERMAL-MAGNETIC SWITCH	COMMUNTEUR MAGNÉTIQUE-THERMIQUE	THERMISCHER-MAGNETISCHER SCHALTER
T	418242	TURBINA 4,0 HP	TURBINE 4,0 HP	TURBINE 4,0 HP	TURBINE 4,0 HP



**Lista parti di ricambio**  
**Spare parts list**  
**Liste des pièces détachées**  
**Ersatzteilliste**

# CA 40

**Ref. CA40/2/2007/SAP**



Timbro e firma del rivenditore  
Dealer's signature and stamp  
Cachet et signature du Distributeur  
Stempel und Unterschrift des Verkäufers

